

INSTALLATION INSTRUCTION

A GOOD INSTALLATION ENSURES LASTING WINDOW PERFORMANCE.

BUILDING CODES, ENVIRONMENTAL CONDITIONS, APPROVED SHOP DRAWINGS MAY VARY & SUPERSEDE THE PROCEDURES CONTAINED BELOW. THE RESPONSIBILITY FOR COMPLIANCE IS THE PROJECT'S OWNER(S), INSTALLERS, ARCHITECT, INSPECTORS, & BUILDING SCIENTISTS.

1. HANDLE CAREFULLY
 2. STORE WITH NON-ABRASIVE SEPARATORS BETWEEN FRAMES. WINDOWS SHOULD BE STORED IN A PLACE PROTECTED FROM WEATHER.
 3. ALTERATIONS – WINDOWS SHOULD NOT BE LOAD BEARING AFTER INSTALLATION. WINDOWS SHOULD NOT BE MODIFIED TO ACCOMMODATE AIR CONDITIONERS, EXHAUST FANS, ETC.
 4. R.O. – PRODUCT WAS DEVELOPED & TESTED IN A WINDOW WALL INTERFACE SYSTEM DESIGNED TO MANAGE WATER. SEE BRICK VENEER SILL EXAMPLE 4) BELOW FOR LOW TO MODERATE DESIGN PRESSURE REQUIREMENTS.
 5. ANCHORAGE – WINDOW FRAMES SHOULD BE SET PLUMB, SQUARE, SHIMMED AND SECURED TO SURROUNDING STRUCTURE. WINDOW ANCHORAGE MUST BE SUFFICIENT TO MEET STRUCTURAL REQUIREMENTS OF LOCAL BUILDING CODES. ALLOW AT LEAST 6mm (+1/4")SPACE BETWEEN THE FRAME AND ROUGH OPENING FOR SHIMMING AND ADJUSTMENT. ALWAYS ADJUST ANCHOR POSITION, SHIMMING THICKNESS TO MAINTAIN STRAIGHT AND PARALLEL LINES BETWEEN SASH AND FRAME. ENSURE ADEQUATE AND LEVEL SUPPORT OF THE SILL.
- SHIMS REQUIRED TO SUPPORT INTERIOR & EXTERIOR OF WINDOW FRAME AT ALL ANCHORS & ESPECIALLY AT SILL.
- 6a. CORNER ANCHORS – SECURE APPROXIMATELY 100mm (4") FROM THE CORNERS.
 - 6b. PERIMETER ANCHORS – SPACING SHOULD NOT EXCEED 600mm (24") ON CENTER.
 - 6c. MULLION AND TRANSOM ANCHORS – ALWAYS ANCHOR WITHIN 100mm (4") FROM MULLION OR TRANSOM (IT IS ALWAYS A CRITICAL AREA FOR ANCHORAGE).
 7. PERIMETER CAVITIES – BETWEEN WINDOW FRAMES AND ROUGH OPENING (R.O.). INSULATE CONTINUOUS AROUND INNER PERIMETER OF WINDOW WITH LOW EXPANSION FOAM. NOTE THAT AN INSULATED CAVITY IMPROVES THERMAL PERFORMANCE.
 8. CAULK THE EXTERIOR PERIMETER TO PROVIDE SEAL BETWEEN WALL AND WINDOW TO ENSURE CONTINUITY OF WEATHER TIGHTNESS. (AIR BARRIER)
 9. CAULK AND/OR TAPE THE INTERIOR PERIMETER TO PROMOTE CONTINUITY OF VAPOR BARRIER TO MINIMIZE RISK OF CONDENSATION WITHIN THE CAVITY & TO MEET TESTED AIR & WATER RESISTANCE LEVELS.
 10. MAINTENANCE – WASH GLASS & FRAME WITH NON-ABRASIVE CLEANER & WATER. LUBRICATE WITH ONLY SILICONE LUBRICANT SPRAY – HARDWARE & ALL WEATHERSTRIP EVERY SIX MONTHS MIN. TO MAINTAIN EASE OF OPERATION.

RECOMMENDED MINIMUM ANCHOR LOCATIONS (SCREW, STRAP ANCHOR OR NAILING FIN)

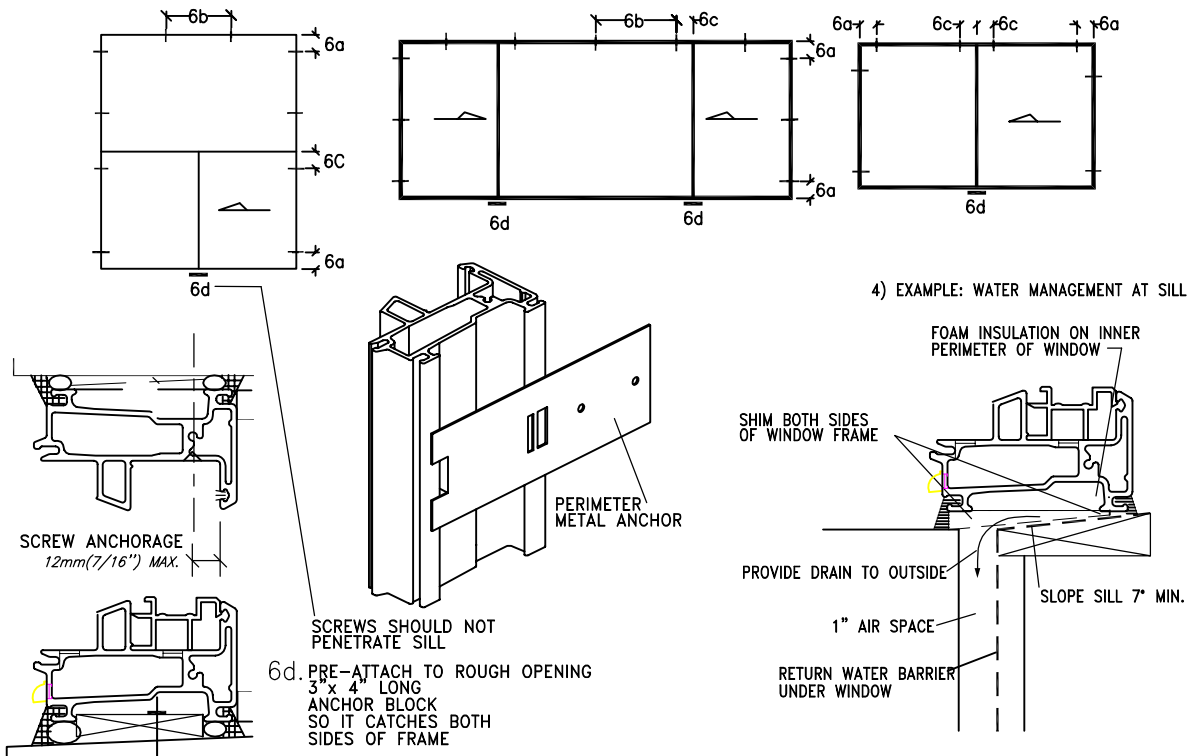

ITEM.	QTY.	DWG.NO./CAT.NO.	DESCRIPTION	MATERIAL														
<p>INLINE FIBERGLASS</p> <p>30 Constellation Court Toronto, Ontario M9W 1K1</p>			<p>SHEET 1/1</p> <table border="1" style="width: 100%; border-collapse: collapse;"> <tr> <th style="width: 10%;">NO.</th> <th style="width: 10%;">REVISION</th> <th style="width: 10%;">DATE</th> </tr> <tr> <td style="text-align: center;">1.</td> <td style="text-align: center;">K.C.</td> <td style="text-align: center;">Nov.06</td> </tr> <tr> <td> </td> <td> </td> <td> </td> </tr> <tr> <td> </td> <td> </td> <td> </td> </tr> </table>		NO.	REVISION	DATE	1.	K.C.	Nov.06							<p>INSTALLATION INSTRUCTION</p>	
			NO.	REVISION	DATE													
			1.	K.C.	Nov.06													
DR. BY.	G.R.																	
DATE	Jun. 06																	
SCALE																		
<p style="font-size: 24pt; font-weight: bold;">800-000</p>																		